



EZ Way, Inc.

## Service Manual

**Model L500 and L600 Smart Lift™**



EZ Way, Inc.

# Table of Contents

<b>Parts Breakdown. . . . .</b>	<b>3</b>
<b>Maintenance Checklist . . . . .</b>	<b>5</b>
<b>Smart Lift™ Operating Instructions . . . . .</b>	<b>7</b>
<b>Scale Calibration . . . . .</b>	<b>8</b>
<b>Advanced Smart Lift™ Features . . . . .</b>	<b>9</b>
<b>Wiring Schematic . . . . .</b>	<b>.12</b>
<b>Trouble-Shooting Guide . . . . .</b>	<b>.13</b>



EZ Way, Inc.

# L500 – L600 Parts Diagram

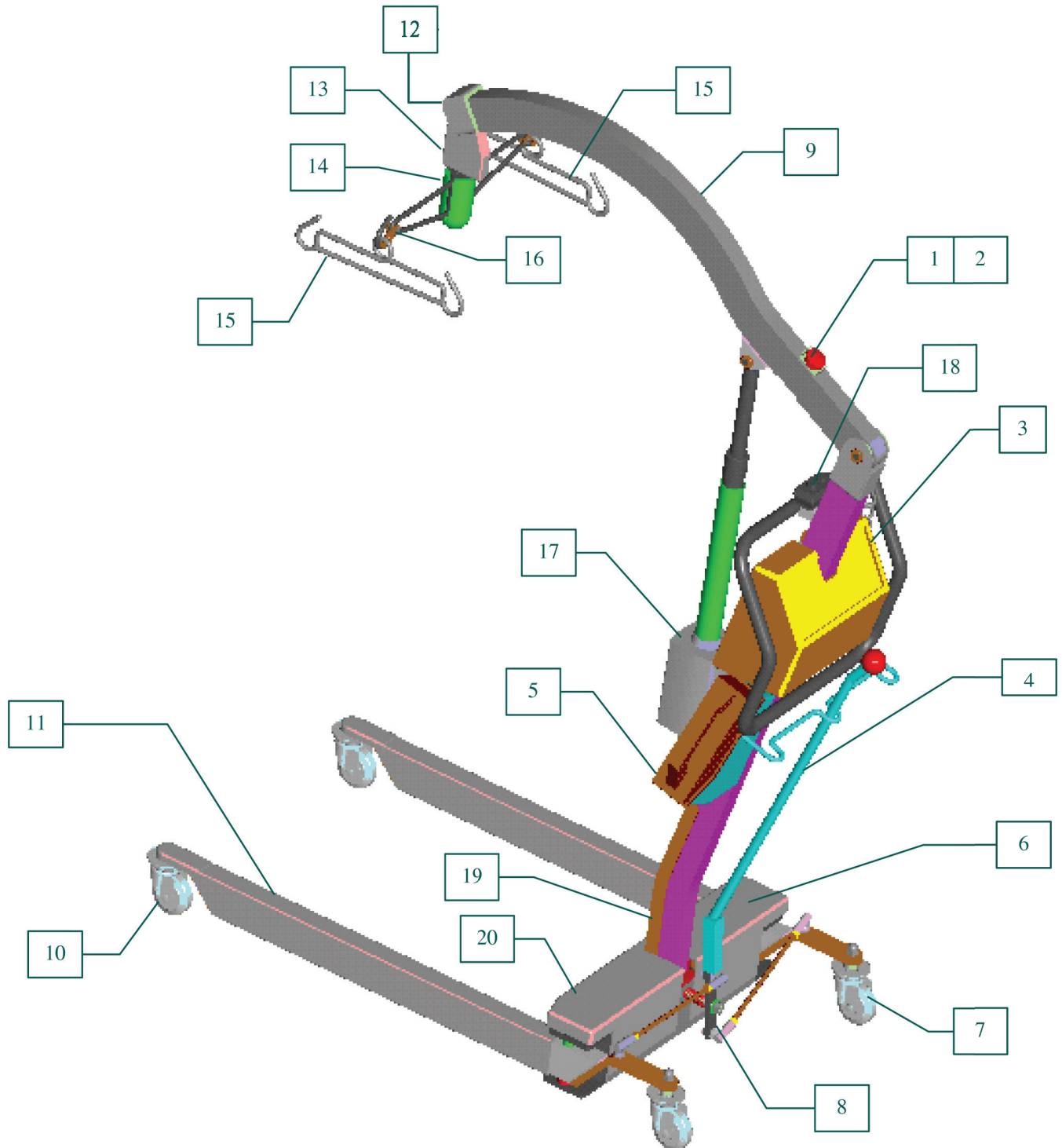



## 500# EZ Smart Lift™ Model L500

<u>Item</u>	<u>Part No.</u>	<u>Description</u>
1	11842	Switch Emergency Stop Button Lift & Stand
2	11817	Guard Emergency Stop Switch Lift
3	12049	Shroud Assembly Smart Lift with Scale
	12050	Shroud Assembly Smart Lift without Scale
4	13316	Handle Spreader Assembly Lift & Stand
5	11871	Battery Pack Assembly UL
6	13502	Cover, Base Assembly Lift 500 lb.
7	12057	Caster Rear Lift & Stand
8	13310	Bar Pivot Chrome Plated Lift & Stand
9	11200	Boom Lift 500 lb. & 600 lb.
10	11790	Caster Front Lift & Stand
11	14510	Cover, Leg Lift, 500 lb. & 600 lb.
12	11540	Pad Boom End Lift (Helmet)
13	17005	Hanger Assembly with Scale S-Beam
	17001	Hanger Assembly Non-Scale Lift 500 lb. 600 lb.
14	15500	Pad Green Hanger Assembly Lift
15	12012	Hanger Sling Assembly
16	12708	Spreader Bushing Kit
17	12476	Actuator Assembly - Lift
18	12706	Hand Control Assembly
19	12146	Bed Guard
20	12788	Base Assembly Lift 500 lb. Std Casters

## 600# EZ Smart Lift™ Model L600

<u>Item</u>	<u>Part No.</u>	<u>Description</u>
1	11842	Switch Emergency Stop Button Lift & Stand
2	11817	Guard Emergency Stop Switch Lift
3	12049	Shroud Assembly Smart Lift with Scale
	12050	Shroud Assembly Smart Lift without Scale
4	13316	Handle Spreader Assembly Lift & Stand
5	11871	Battery Pack Assembly UL
6	12816	Cover, Base Assembly Lift 600 lb.
7	11786	Caster Rear Lift & Stand
8	13310	Bar Pivot Chrome Plated Lift & Stand
9	11200	Boom Lift 500 lb. & 600 lb.
10	14500	Caster Front Lift & Stand
11	14510	Cover, Leg Lift, 500 lb. & 600 lb.
12	11540	Pad Boom End Lift (Helmet)
13	17005	Hanger Assembly with Scale S-Beam
	17001	Hanger Assembly Non-Scale Lift 500 lb. 600 lb.
14	15500	Pad Green Hanger Assembly Lift
15	12012	Hanger Sling Assembly
16	12708	Spreader Bushing Kit
17	12014	Actuator Assembly - Lift
18	12706	Hand Control Assembly
19	12146	Bed Guard
20	12901	Base Assembly Lift 600 lb. Std Caster



EZ Way, Inc.

"Your Total Patient Lift Solution"



## EZ Way Smart Lift™ Safety & Maintenance Checklist

The EZ Way Smart Lift™ requires a minimum of servicing to keep it in good working order. Nevertheless, it is important that certain basic checks be periodically made by maintenance staff to ensure on-going safety throughout the life of the device.

The manufacturer suggests that the following components and operating points be scheduled for inspection at intervals not greater than six months. Any detected deficiency must be rectified before the lift is put back into service.

- 1** Check wear of hanger assembly bushing by moving hanger assembly up and down. If hanger assembly moves up and down and the thickness of 2 quarters can be inserted between hanger assembly and load cell the hanger assembly needs to be replaced.

NEEDS REPLACEMENT

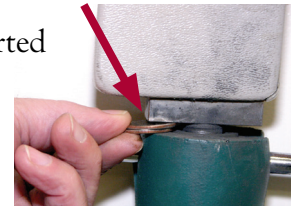

- 2** Check all bolts to ensure they are tight.

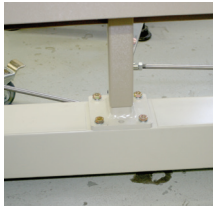

BASE

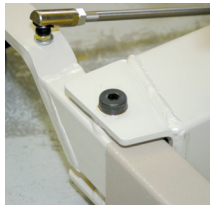

PIVOT

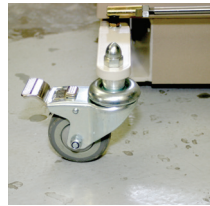

REAR WHEEL



FRONTWHEEL

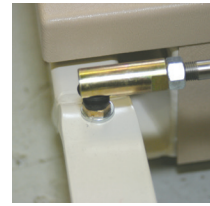

LINKAGE

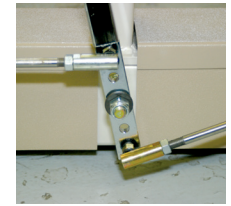

SPREADER

- 3** Check boom to hanger assembly pivot bolt, peel rubber back to assure nut is tight and cotter pin is in place. Check boom to mast pivot bolt by removing plastic cap to assure nut is tight and cotter pin is in place. If plastic cap is missing order replacement.



BOOM TO HANGER



BOOM TO MAST

- 4** Check the point where sling hanger and hanger spreader bar meet. If excessively worn, replace the bushings immediately. The hanger spreader and sling hanger wear points need to be checked for wear. If hooks appear worn, call EZ Way for instructions.

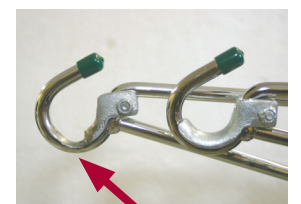

BADLY WORN

- 5** Check mounting bolts of actuator top and bottom. Pay particular attention to top bolt hole for elongation.



ELONGATED



TOP OF ACTUATOR

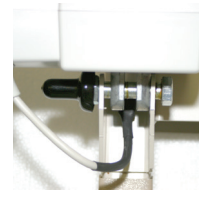

BOTTOM OF ACTUATOR



**Check actuator for the following.**

- Inspect the plastic housing for any dents or cracks.
- Inspect the cables to see if they have been cut or pinched.
- See if the actuator appears deflected when fully extended under load.
- Verify that the mounting points do not have any cracks or other defects.
- Apply a heavy grease to actuator mounting pins as needed.
- Verify that the inner or outer tubes do not have any dents, dings, or large scratches in them.

**Contact EZ Way's Service Department if the actuator shows any signs of the issues listed above.**

- 6** Test the Emergency Stop Switch. If the switch does not stop the lift when activated, call the EZ Way Service Department immediately!
- 7** Perform a functional test of the emergency lowering feature of the lift actuator if it is so equipped.
- 8** Perform a functional test of the anti-pinch feature of the lift actuator. This feature turns the actuator off when lowering the lift arm if an obstruction is encountered.
- 9** Check all the wheels and brakes to make sure they are functioning properly. Hair that gets picked up and wrapped in between wheels should be cleaned out so that the lift will roll easily.
- 10** Do a visual check for any damaged, missing or loose parts. Repair as necessary.
- 11** Check the entire sling for damage or wear, including the loops and stitching. If damage or wear is present, discard the sling and order a new one. It is recommended that slings be replaced after one year or if the sling shows any sign of damage or wear.
- 12** At one year intervals, attach a load equivalent to or within 100 lbs of the rated capacity of the lift to the unit. Do not exceed the rated weight capacity. Raise and lower the load with the lift. Listen for any unusual noises while operating the unit. With the test load applied to the lift, check all structural welds for any signs of stress or fatigue cracks. If any unusual noises or cracks are found, stop using the lift and call the EZ Way Service Department immediately!
- 13** When cleaning the lift, do not spray any liquid cleaners directly onto the front panel graphics. To clean, use a glass cleaner such as Windex, dampen a cloth and wipe the panel.

**IMPORTANT NOTICE**

It is the responsibility of the purchaser to ensure that regular maintenance inspection is conducted on this device by competent staff.

DATE COMPLETED: \_\_\_\_\_

COMPLETED BY: \_\_\_\_\_

PASS / FAIL: \_\_\_\_\_

MODEL & SERIAL NO.: \_\_\_\_\_

EQUIPMENT PURCHASE DATE: \_\_\_\_\_



## MOVING LIFT

To move the arm, press and hold the key for the desired direction of travel.

## WEIGHING

### Capturing new weight

To capture a new weight, press the Weight key. While capturing the new weight a “?” will be seen indicating that the control is waiting for a weight to lock in. Once the weight has locked in a “\*” will be seen. At this point, the weight has been locked in and saved into memory as the next recall weight.

### Recall last weight

To recall previous weight, press the ‘down’ key and then ‘weight’ key. The weight will be displayed with a # symbol indicating that the weight is recalled.

## MENUS

### Navigating through menus

1. Pressing the Up or Down keys will move (also described as ‘scrolling’ below) through menu items.
2. Pressing the Right Toggle Switch (also described as ‘enter’ below) will enter into a menu selection.
3. Pressing the Left Toggle Switch (also described as ‘exit’ below) key will exit the menu selection.

### Changing parameter values

1. Pressing the Up or Down keys will change the parameter value.
2. Pressing the Right Toggle Switch will lock the value into memory.
3. Pressing the Left Toggle Switch will back out of the parameter without saving the value.

### Enter Customer Settings menu/ Weight calibration

1. After power up sequence, press and hold the Down key followed quickly by the Up key and hold both keys for 5 seconds.
2. Back out of Customer Settings by hitting left toggle switch.



## SCALE CALIBRATION PROCEDURE

1. **Nothing should be hanging from the hanger/spreader assembly except the sling hangers.**  
During the time the lift is turned ON and the battery level is displayed, the microprocessor is resetting Zero.
2. Press the **“ON/OFF”** key to power up the unit.
3. **Pick up an exact and known weight** (preferably 200 lb.). (Note: Once in the calibration menu, the lift is no longer able to move.)
4. Press the **“WEIGHT”** key to ensure the scale is functional.
5. Enter the calibration menu. After power up sequence, press and hold the **“DOWN”** key followed quickly by the **“UP”** key and hold both keys for 5 seconds.
6. Press the **“UP”** key to calibration menu. Press **Enter** (right toggle) twice.
7. Scroll to the proper calibration weight and enter selection. (Note: If sling is not attached, subtract 1.5 lb.)
8. **“Begin weight calibration”** is displayed. Press **Enter** (right toggle), select **Yes**, and press **Enter** (right toggle) to execute calibration. Display shows **“CALIBRATING”**.
9. When the display leaves this menu selection, it will have been calibrated to the selected weight. Exit the calibration menu.
10. Press **“WEIGHT”** key to verify calibrated weight to 1% accuracy. Calibration is now complete.





## BATTERY MESSAGING

### Charge Battery – For Battery Maintenance

When the battery level gets below 22.7 volts, the display reads ‘CHARGE BATTERY’.

### Swap Battery – For Battery Protection

When the battery level gets below 22.3 volts, the display reads ‘SWAP BATTERY’ and only allows the unit to go in the down direction.

## REMINDER MESSAGING

### Inspection Overdue – For Scheduled Maintenance

The purpose of the inspection overdue reminder is to notify the customer that the lift needs to be inspected every 30 days.

## FAULT MESSAGING

### Duty Cycle Fault – For Actuator Protection

The lift actuators are rated for a specific duty cycle. What this means is that for every 20 minutes of elapsed time, the lift is rated to run 5 minutes. If the lift is operated in excess of 5 minutes at a time, the actuator may be damaged. When the duty cycle fault occurs, the following message comes up: ‘Actuator Duty Cycle Fault...Cooling’. When this fault occurs, the customer can lower the patient. After lowering, the customer will need to wait 15 minutes to cool the actuator motor.

### Actuator Overload – For Arm Protection

1. When an Up or Down command is executed, the circuit board monitors current consumed by the actuator. If the actuator consumes too much current, the control will recognize this condition.
2. At this time an ‘Actuator Overload’ message will display. The ‘Actuator Overload’ may result from lifting a patient/object that is too heavy, arm pinched against obstruction, or mechanical failure (internal actuator binding, etc.).
3. To override an ‘Actuator Overload’, press the down key. The arm will only operate in the down direction during a current overload. Note: This feature is available on all scale and non-scale units.

### Weight Overload – For Arm Protection

1. When an Up or Down command is executed, the control monitors weight readings from the load cell. If the weight is measured too high, the control will recognize this condition.
2. At this time a ‘Weight Overload’ message will display. The Weight Overload may result from accidental lifting of a trapped sling or accidental lifting of an overweight patient.
3. To override a ‘Weight Overload’, press the down key. The arm will only operate in the down direction during a Weight Overload. Note: This feature is only available on scale units.



## ADVANCED DIAGNOSTICS

### Real Time Current – For Actuator Diagnostics

1. When the display shows “EZ Lift Awake”, press the hidden key. Now whenever the lift is in motion, the real time current will be shown.
2. The Real Time Current function will disable after power cycling the unit.

### Real Time Voltage – For Battery Diagnostics

1. In the case of a possible battery or connection issue the battery voltage can be monitored real-time. Go to the Customer Settings menu.
2. Press the Enter key several times until you see “Volts = ...”.

## CUSTOMER SETTINGS MENU (FULL DESCRIPTIONS)

Within the Customer Settings Menu there are several functions that provide customer feedback. The functions include; an Inspection Reminder, lift usage, and diagnostic information. Below is a description of each function within the Customer Settings Menu.

### Inspection Reminder – For Scheduled Maintenance

The Inspection Reminder function tracks the last inspection occurrence. When the duration of time since the last inspection exceeds 30 days a reminder message will appear when the unit is powered up. The purpose of the inspection reminder is to notify the customer that the lift or stand needs to be inspected with the ‘EZ Way Safety & Maintenance Checklist’ form (see attached). When the checklist is complete the reminder is to be reset in the Customer Settings Menu as described below.

1. To enable/disable the Inspection Reminder enter the Customer Settings Menu.
2. Press enter. Scroll to Inspection Reminder. Press enter. Scroll to choose Yes or No. Press Enter.
3. Press Exit twice.

### Inspection Complete

1. If ‘INSPECTION OVERDUE’ appears during power up complete the ‘EZ Way Safety & Maintenance Checklist’.
2. Enter the Customer Settings Menu.
3. Press enter. Scroll to Inspection Complete. Press enter. Scroll to choose Yes. Press Enter.
4. Press Exit twice.

### Overweight Counts – For Diagnostic Tracking with Scale

The Overweight Counts function tracks ‘Weight Overload’ occurrences. When a ‘WEIGHT OVERLOAD’ occurs the ‘Overweight Counts’ register increments one. This read-only information provides customer feedback for; accidental lifting of a trapped sling, or accidental lifting of overweight patient. This information is available for units with the scale option only.



## **Actuator Minutes – For Tracking Lift Usage**

The Actuator Minutes function tracks the accumulated amount of raising and lowering time of the actuator. With each minute of runtime the 'Actuator Minutes' register increments one. A typical lift takes one minute of runtime. This read-only information provides accurate customer feedback of lift usage within the care facility. In the event of an actuator replacement the 'Actuator Minutes' register can be reset by calling an EZ Way Service representative.

## **Actuator Overload Counts – For Diagnostic Tracking with Actuator**

The Actuator Overload Counts function tracks Actuator Overload occurrences. When an 'ACTUATOR OVERLOAD' occurs the 'Actuator Overload Counts' register increments one. This read-only information provides customer feedback for; accidental lifting of a trapped sling, accidental lifting of arm against obstruction, or accidental lifting of overweight patient.

## **Lift/Stand Total Minutes – For Tracking Lift Usage**

'Lift/Stand Total Minutes' function tracks the accumulated amount of raising and lowering time of the actuator on the lift. The 'Lift/Stand Total Minutes' is not reset when an actuator is replaced. This read-only information provides accurate customer feedback of lift usage for the entire life of the lift.

## **Volts= • For Battery Diagnostics**

The 'Battery Voltage' function tracks the real-time voltage of the battery. This information is useful in diagnosing issues related to battery level.

## **SW Rev. – For Software Diagnostics**

The 'Software Revision' is used for tracking software changes. For example if the original code begins with version 1.3 and changes are made to the original code the next revision of code will display version 1.4. New controls with version 1.8 will have software updates included.



## Emergency Stop Switch

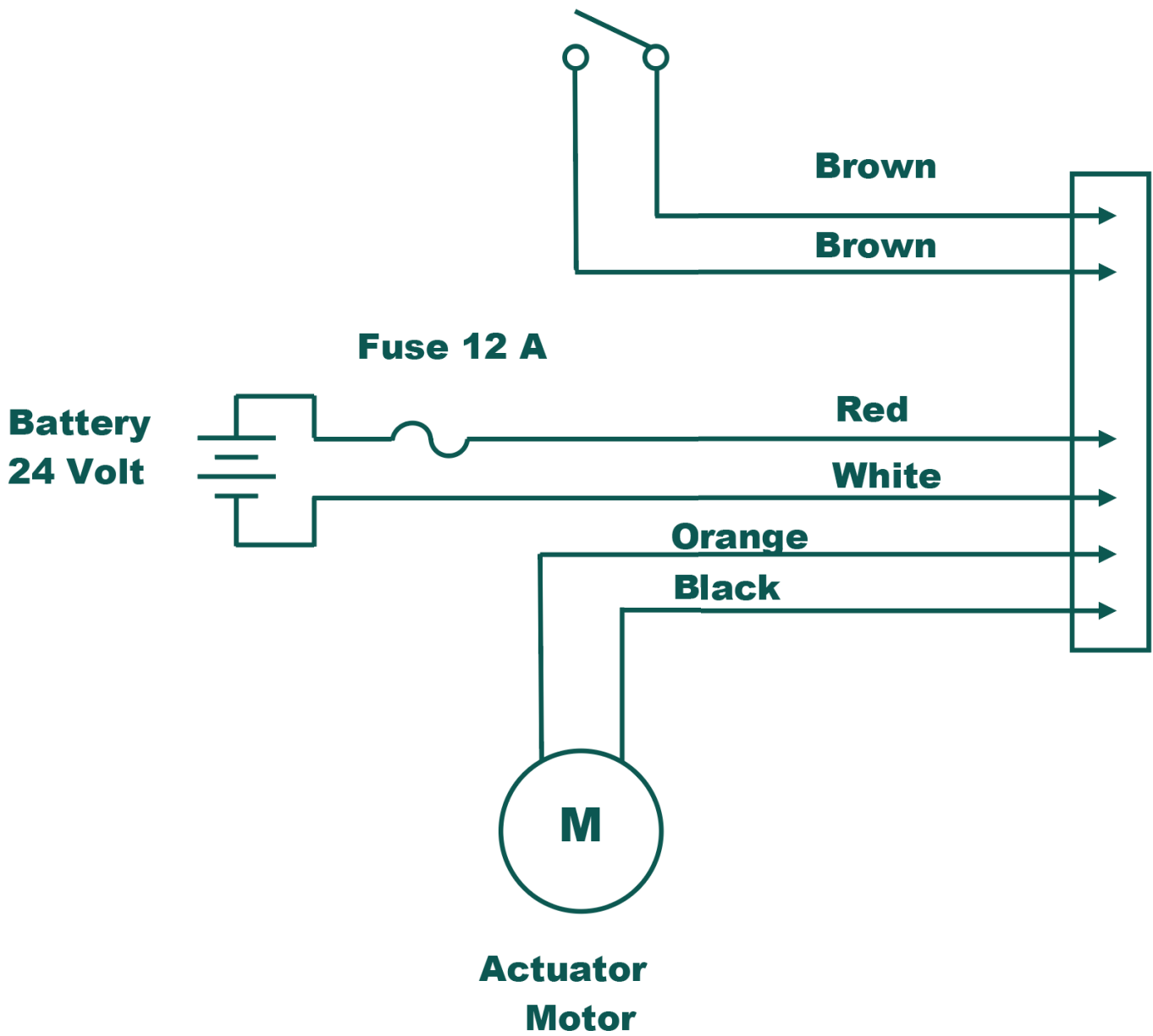



Problem	Solution
Machine will not turn on	<p>Check battery. Make sure it is fully charged.</p> <p>Check battery receiver plug. Make sure prongs are not bent or pushed in. Call EZ Way Service for replacement.</p> <p>Check fuses.</p> <p>Check green connector on PC board for good connection. Make sure all wires are tight.</p> <p>Make sure on/off button is not flattened out.</p> <p>Check if green LED is flashing on board. Flashing LED indicates the PCB is getting power.</p> <p>Make sure W6 jumper is in place.</p>
No up/down but display works	<p>Check connection at actuator.</p> <p>Check voltage at actuator connection. If 24 VDC are present then the actuator may need replaced.</p> <p>If voltage is not good, check black and orange wires on green connector at circuit board. Make sure they are not loose.</p> <p>Call Service if voltage is not good and connection is good.</p>
Continuous up/down	<p>Unhook toggles and airlines from board. If problem still persists call EZ Way Service.</p>