



EZ Way, Inc.

EZ Way Smart Lift™

Features and Specifications – 500 and 600 lb. Capacities

Frame:

- All steel construction
- Three position leg spreader (hand operated)
- Optional low base with 2 1/16" clearance
- Baked epoxy powder coated paint
- Weight with battery pack - 123 pounds
- Lift range 42.5" total travel

Covers and Bumpers:

- ABS Plastic covers on base and legs

Casters:

- Front; double steel ball bearing with swivel head and rubber bumpers
- Rear; locking swivel head and wheel

Hand Control:

- Impact resistant pneumatic hand control with magnet

Motor Actuator:

- Acme screw design
- Built in safety switch for down stroke
- Automatically stops at top and bottom of stroke
- CE certified
- Manual lowering capability if there is a power failure

Battery Pack: (2 per Lift)

- ABS plastic housing with handle
- 2 - 12 volt batteries/5.0 Amp hr = 24 volt output
- Approximately 180 lifts per charge

Battery Charger Unit:

- 110 volt input/24 volt output
- Approved to UL Standards
- 6 to 8 hour charge



Electronics:

- ABS Plastic shroud
- Three methods to control the unit, thumb switches, front panel switches, and hand control
- Large backlit LCD window displays battery level, weight (if equipped), and diagnostic functions
- Automatically shuts off after 20 minutes of non-use
- Over-discharge protection
- Usage time captured: Lift usage time is captured in minutes, great for tracking frequency of use
- Overload protection
- Weight recall: the last weight taken is retained until a new weight is taken
- Displays weight in pounds or kilograms



EZ Way, Inc.

EZ Way Smart™ Lift

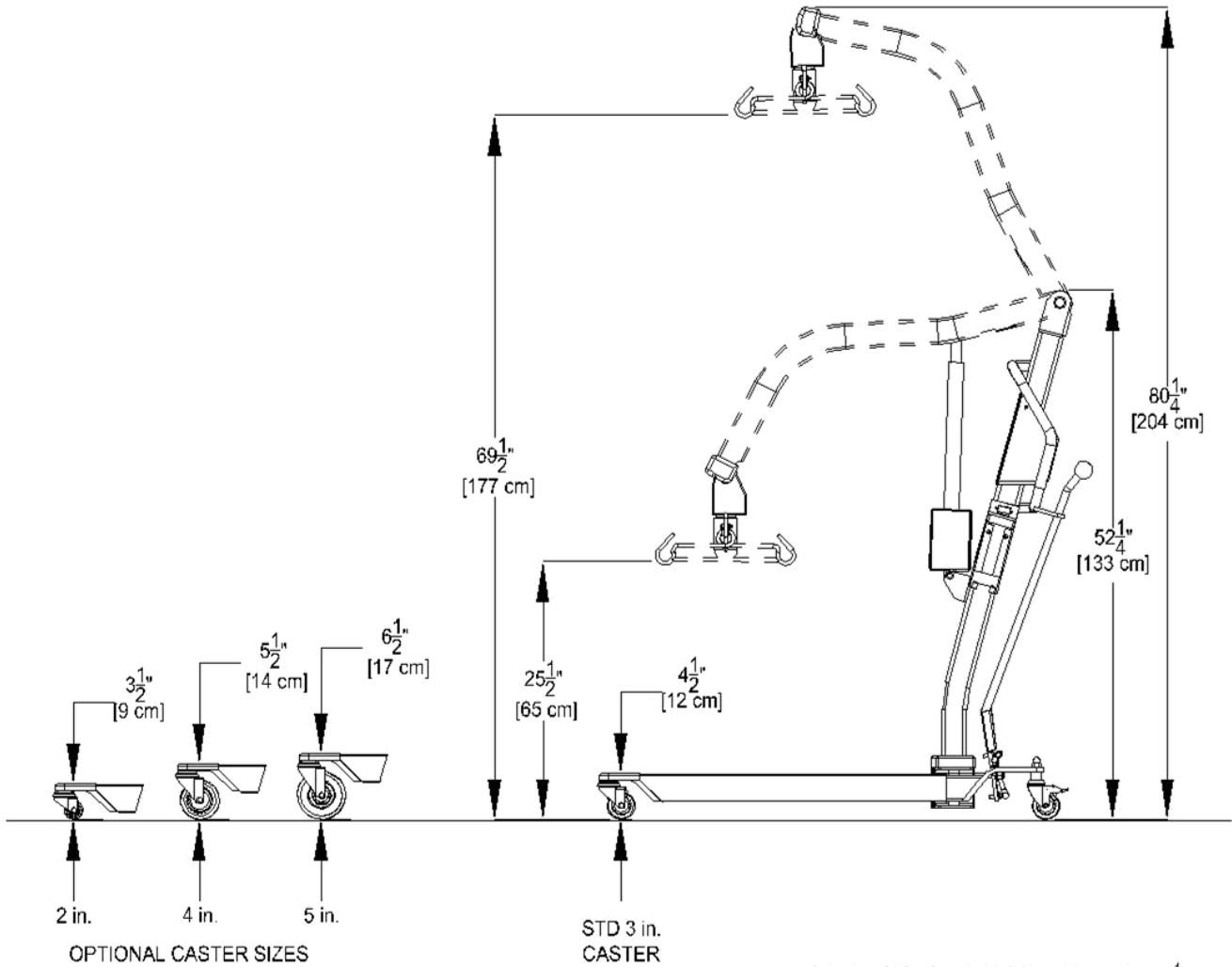
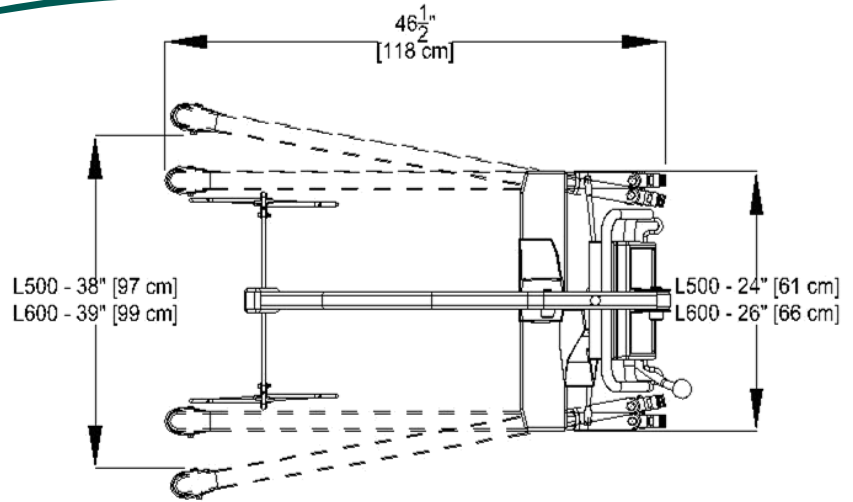

*DIMENSIONS ARE ACCURATE WITHIN $\frac{1}{4}''$

EZ Way, Inc. • (800) 627-8940 • Fax (712) 542-1899 • www.ezlifts.com

⚠ WARNING: Cancer and Reproductive Harm - www.P65Warnings.ca.gov.

Form 2-189
Rev. 1/31/19